



COLLABORATIVE ROBOTS TECHNICAL SPECIFICATION

i16



INDEX

- 1. Introduction**
- 2. Features and Benefits**
- 3. Supply Description**
 - 3.1. Manipulator**
 - 3.1.1. Axis Movement**
 - 3.2. Controller**
 - 3.3. Teach Pendant**
- 4. Dimensions**
- 5. Commercial Proposal**
- 6. Terms & Conditions**
- 7. Conclusion**



Introduction:

DECELER – AUBO Cobots

DECELER is a new gen engineering organisation focusing on three verticals of the business FACTORY AUTOMATION - COBOT AUTOMATION - SAFETY AUTOMATION

DECELER started as a small business in 2013, and has always been driven by technology, core values and ethics. Our brand grows by adding new technology products with an expansion of geography in a periodic manner understanding the necessity of customer demands in advance through our long vision on

Deceler's growth is built on three main roots which are customers – employees – business associates and along with these three combinations we also offer good products with best service that helps customers to gain trust on us which leads to an increase in their numbers. Deceler spreads its operations across India and deals

AUBO COBOTS - Features and Benefits:

Safer

The products have passed the certification of PL=d, CAT3), ISO 10218 CE, UL, KCs, CR, SEMI S2 etc, all core parts are localized, and level-10 collision detection and sensor safety testing are supported, so no safety protection is required.

More open

The open system platform supports multiple communication methods, SDK and API, and can establish communication with multiple peripheral equipment such as terminal jig, visual and mobile equipment.

More precise

With repeatability of $\pm 0.05\text{mm}$, high-precision work can be completed continuously for a long time, thus greatly enhancing the production yield.

Simpler

Robots can be operated by many methods including drag teaching, coordinate positioning, path planning and offline programming. The visual interface is simple and easy to learn.

Wider

The whole series products have a loading capacity of 3 to 16KG, which can cover different applications in each industry and have a wide range of applications.

Supply Description:

Payload - 16kg

Weight - 38kg

Repeatability - ± 0.03 mm

Reach - 967.5mm



Manipulator:

Degrees of freedom - 6

Reach(mm) - 967.5

Payload(kg) - 16

Weight(kg) - 38

Mounting surface diameter(mm) - $\varnothing 220$

Repeatability (mm) - ± 0.03

Linear velocity (m/s) - ≤ 3.0

Average power (W) - 600

Peak power (W) - 2000

Ambient temperature ($^{\circ}\text{C}$) - 0-50

Ambient humidity - 25%-90%

Installation orientation - Any ceiling, floor, wall

IP Classification - IP54

Axis Movements:

Axis Movement	Working range (°)	Maximum speed (°/s)
joint 1	± 360	178
joint 2	± 360	178
joint 3	± 360	267
joint 4	± 360	178
joint 5	± 360	178
joint 6	± 360	178

Controller:

- Model - **AUBO-CB-M**
- Dimensions - 380mm*350mm*265mm
- Weight - 15kg
- Cabling Connecting the Robot - 5m (customizable, up to 8m)
- Cabling Connecting the Teach Pendant - 4m
- Communication - Ethernet/Modbus-RTU/TCP, Profinet (optional)
- Interface - SDK (Support C/C++/C#/Lua/Python), Support ROS, API
- Power Supply - 100 240VAC,50-60Hz
- IP Classification - IP43



Control Box I/O	Tool I/O	Control Box	Tool End
I/O Port	Digital in	16(general) /16(safe)	4 (optional)
	Digital out	16(general) /16(safe)	4(optional)
	Analog in	4	2
	Analog out	4	-
I/O Power	Output voltage	24V	0V/12V/24V
	Output Current	3A Max	0.8A

Teach Pendant:



Model - AUBO - TP
 Dimensions - 355*235*54mm
 Weight - 1.57kg
 IP Classification - IP43
 Color - Orange+Black

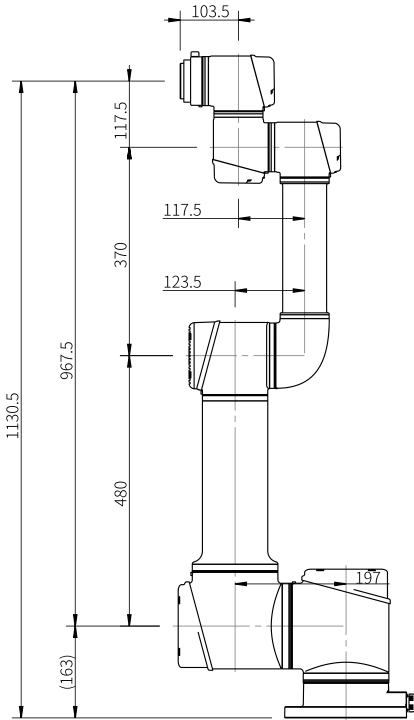

Overall Dimensions

Top View of the Base

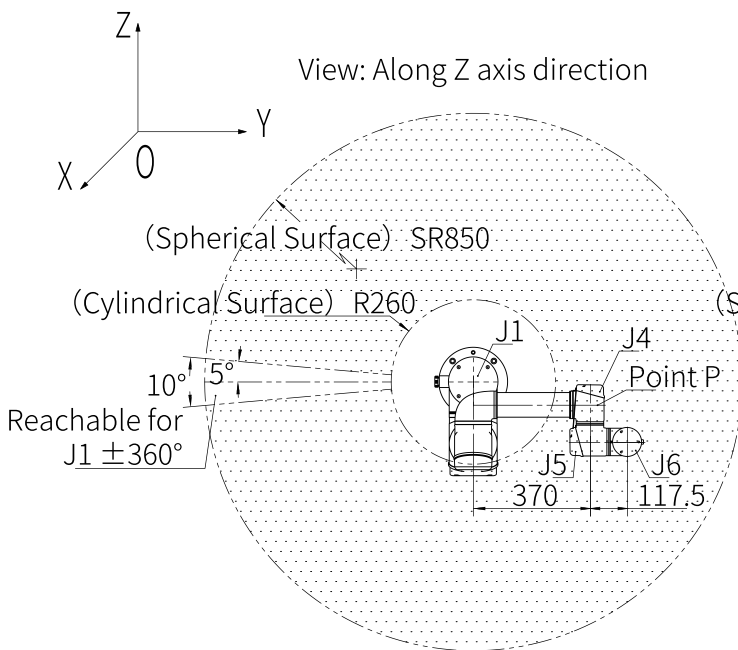
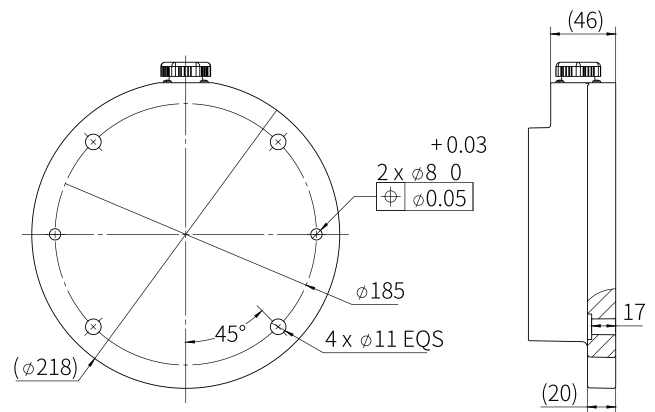

View: Along X axis or Y axis direction

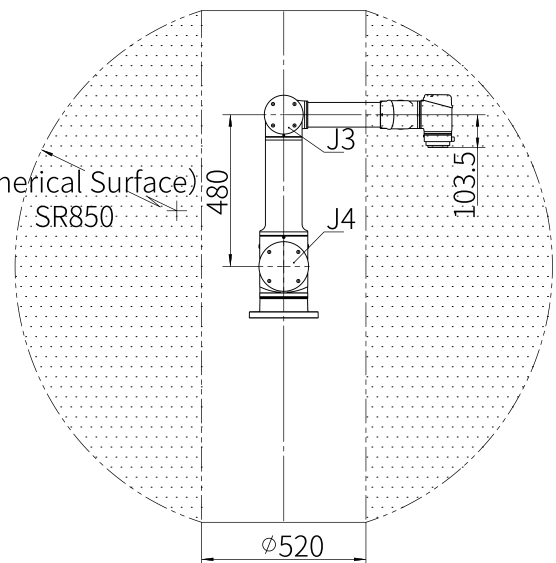

Moving Ranges

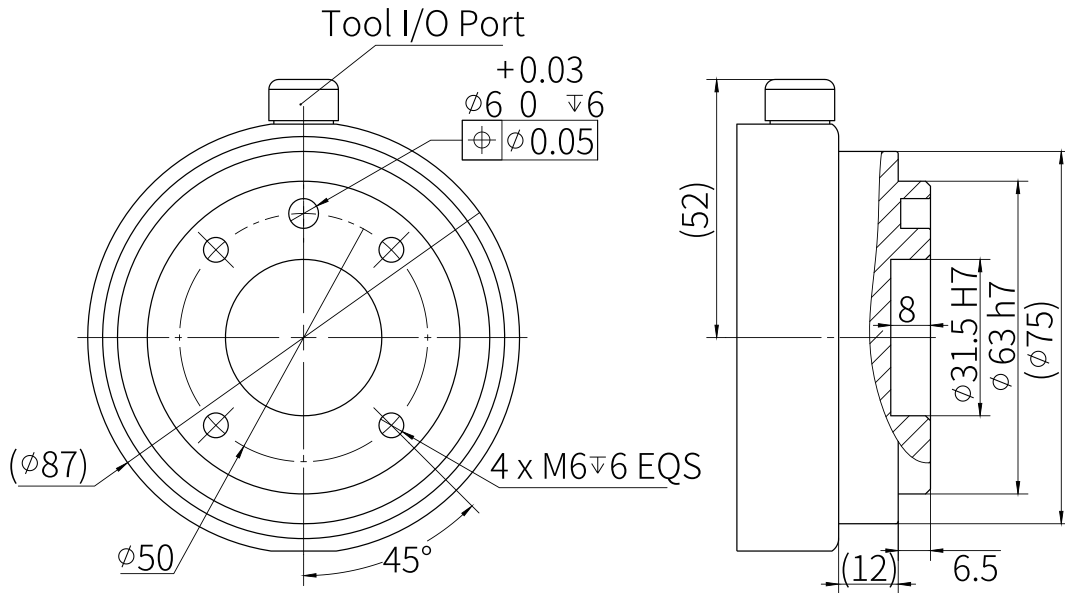

Tool End Flanges

Commercial Proposal

Pls refer **COMMERCIAL OFFER** attached as enclosure and pls refer SQNo for all future communication

Conclusion:

We are very thankful for the opportunity and cooperation that you have provided the requirement to submit our proposal for **Deceler-Aubo Cobot** in your premises.

AUBO

ROBOTICS

APPLICATION CASES



NEW RETAIL / SERVICES



Latte art robot



Beauty mystery box picking



Milk tea workstation



HEALTHCARE



Massage robot



Surgical robot



Reagent testing



MOBILE COBOT



Inspection robot



Intelligent archives



5G Patrol robot



RESEARCH AND EDUCATION



Robot with digital twin technology



Music box assembly line



Education and training platform



OTHER FIELDS



Agricultural picking
High-voltage distribution cabinet operation



High-voltage distribution cabinet operation



Hygiene & cleaning

DECELER VIBROTEK CONTROLS PVT. LTD.

No 38, 1st Floor, Arul Mary Street, Soosaiya Nagar, Noombal, Chennai - 600 077. Tamilnadu, India.

Mob: 94455 25883 Email: sales@deceler.in www.deceler.in
Chennai | Hyderabad | Vizag | Bengaluru | Delhi | Pune | Aurangabad